

Autopilot Tiller Arm Data Sheet

All Tiller Arms are custom machined and are non-returnable - please measure carefully. Bores are machined to +/- .003 tolerance, so the use of a micrometer is highly recommended when measuring.

See current Edson price page for machining charges on special or square bores, keyways or setscrews.

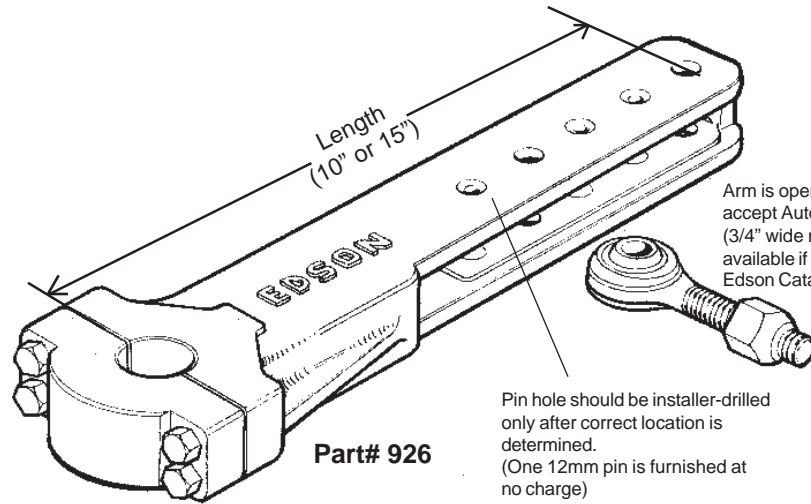

Pin hole should be installer-drilled only after correct location is determined. (One 12mm pin is furnished at no charge)

Company Name: _____		Customer Name: _____	
Boat Type/Model: _____	Length: _____	Year: _____	
Bore Size : _____	Specify: Key _____	Through-Bolt _____	Set Screws _____
If key required, specify size: _____		Length of Arm:(10" or 15") _____	

Sketch Location of Tiller Arm and Autopilot

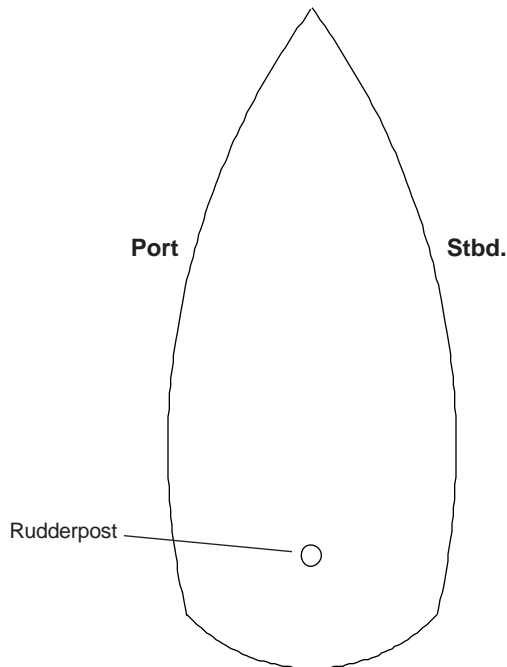

Mark the location of the keyway on the diagram below if it differs from the standard location*.

