

THIS SCHEMATIC IS INTENDED TO PROVIDE AN OUTLINE FOR DESIGNING YOUR SYSTEM. COMPLETE INSTRUCTIONS FOR INSTALLATION CAN BE FOUND IN OUR "PLANNING & INSTALLATION GUIDE", WHICH CAN BE FOUND ON OUR WEBSITE.

**VISIT US ONLINE AT
WWW.EDSONMARINE.COM**

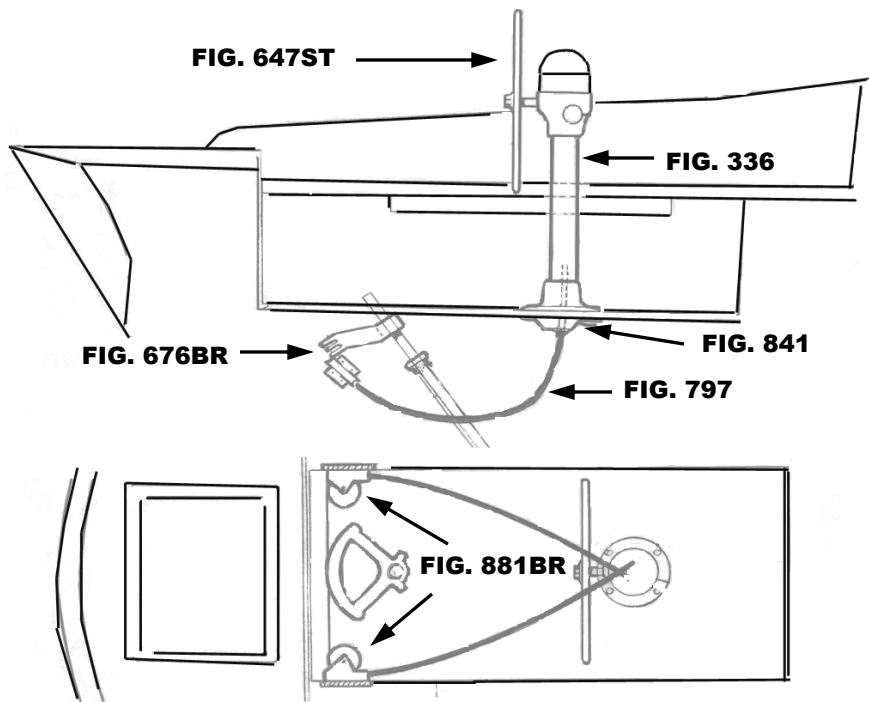

NOTE:
SPECIFY LONGER CONDUIT WHEN POSITIONING THE PEDESTAL FURTHER FORWARD IN THE COCKPIT

STEERING COMPONENTS:

- | | |
|--|---|
| 1 FIG. 336-5-211T | CLASSIC PEDESTAL STEERER/TAPERED |
| 1 FIG. 647ST-24-5 | DISHED DESTROYER WHEEL |
| 1 FIG. 77103 | CHAIN & WIRE ROPE KIT W/HARDWARE <i>[was 774-2S15B9]</i> |
| | <i>(1.5FT #50 CHAIN, 9FT 3/16" 7X19 305 SS WIRE ROPE)</i> |
| 1 FIG. 841-2 | DROP CONDUIT BRACKET |
| 2 FIG. 797-4 | PULL/PULL CONDUIT W/END FITTINGS |
| 2 FIG. 881BR-4AL | UPRIGHT CONDUIT IDLER |
| 1 FIG. 677-8 | OFFSET MANGANESE BRONZE QUADRANT |
| 4 FIG. 646-4HEX | PEDESTAL MOUNTING BOLTS |
| (A FIG. 697 STUFFING BOX/BEARING MAY BE REQUIRED) | |

CAPE DORY 27 (S-769-1)