

Steering Data Sheet



CATALINA 30 (PRIOR TO SEPT. 1986)

S-660

THIS SCHEMATIC IS INTENDED TO PROVIDE AN OUTLINE FOR DESIGNING YOUR SYSTEM. COMPLETE INSTRUCTIONS FOR INSTALLATION CAN BE FOUND IN OUR "PLANNING & INSTALLATION GUIDE", WHICH CAN BE FOUND ON OUR WEBSITE.

VISIT US ONLINE AT
WWW.EDSONMARINE.COM

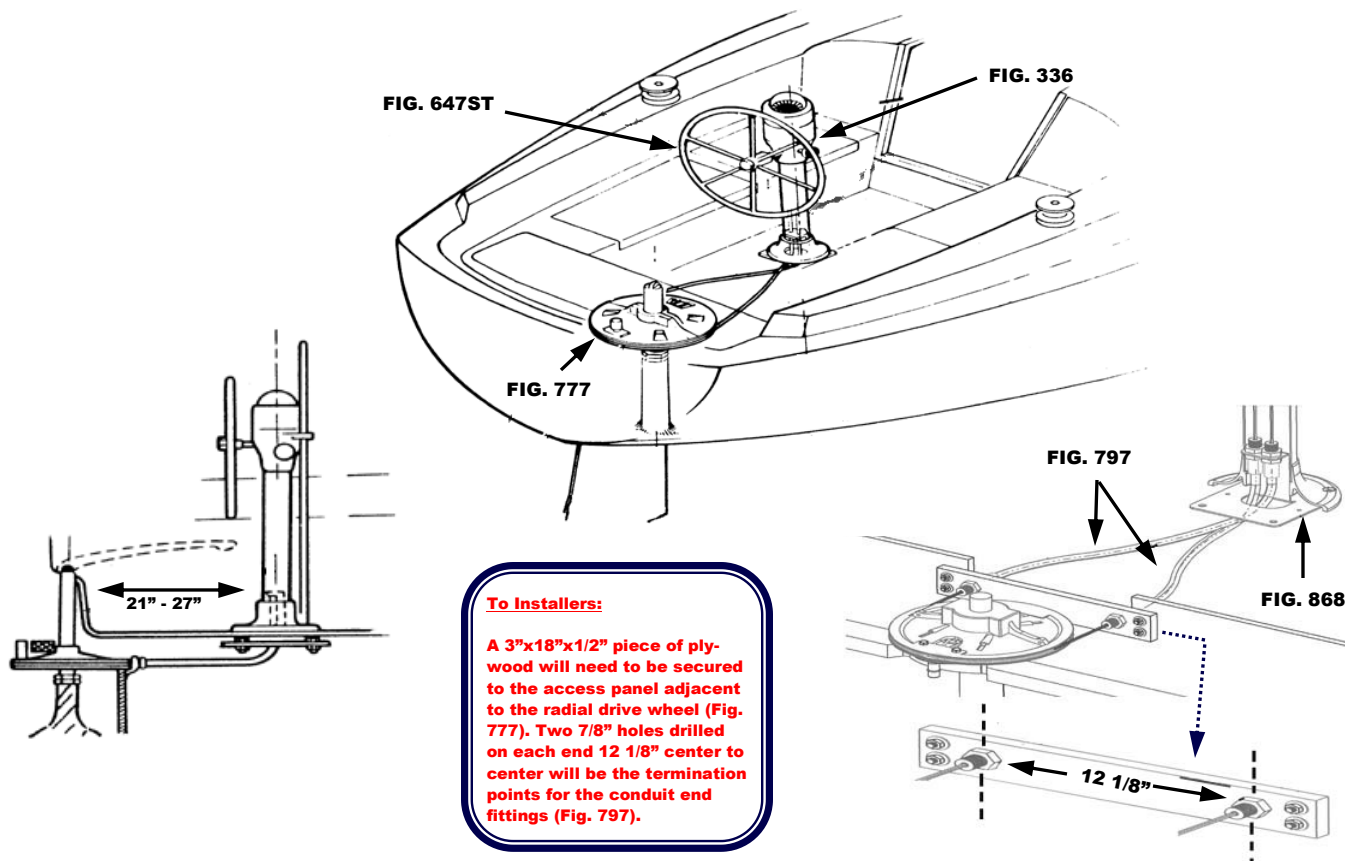

STEERING COMPONENTS:

1 FIG. 336-5-211T
1 FIG. 647ST-24-5
1 FIG. 77103

1 FIG. 868-2
2 FIG. 797-3
1 FIG. 777-6.5
4 FIG. 646-4HEX
1 FIG. 827-3
1 FIG. 697-2.375

**CLASSIC PEDESTAL STEERER/TAPERED
DISHED DESTROYER WHEEL**

CHAIN & WIRE ROPE KIT W/HARDWARE [was 774-2S15B9]
(1.5FT #50 CHAIN, 9FT 3/16" 7X19 305 SS WIRE ROPE)

INTERNAL CONDUIT BRACKET

PULL/PULL CONDUIT W/END FITTINGS

RADIAL DRIVE WHEEL

PEDESTAL MOUNTING BOLTS

TEFLON LUBRICANT

STUFFING BOX/BEARING



146 DUCHAINE BLVD, NEW BEDFORD, MA 02745-1292 Tel: 508-995-9711 Fax: 508-995-5021 FREE FAX: 800-338-5021

CATALINA 30 (PRIOR TO SEPT. 1986) (S-660)