

Steering Data Sheet



S-2 8.0 MID-SHIP COCKPIT (PULL/PULL CABLE SYSTEM)

S-639-1

THIS SCHEMATIC IS INTENDED TO PROVIDE AN OUTLINE FOR DESIGNING YOUR SYSTEM. COMPLETE INSTRUCTIONS FOR INSTALLATION CAN BE FOUND IN OUR "PLANNING &

VISIT US ONLINE AT
WWW.EDSONMARINE.COM

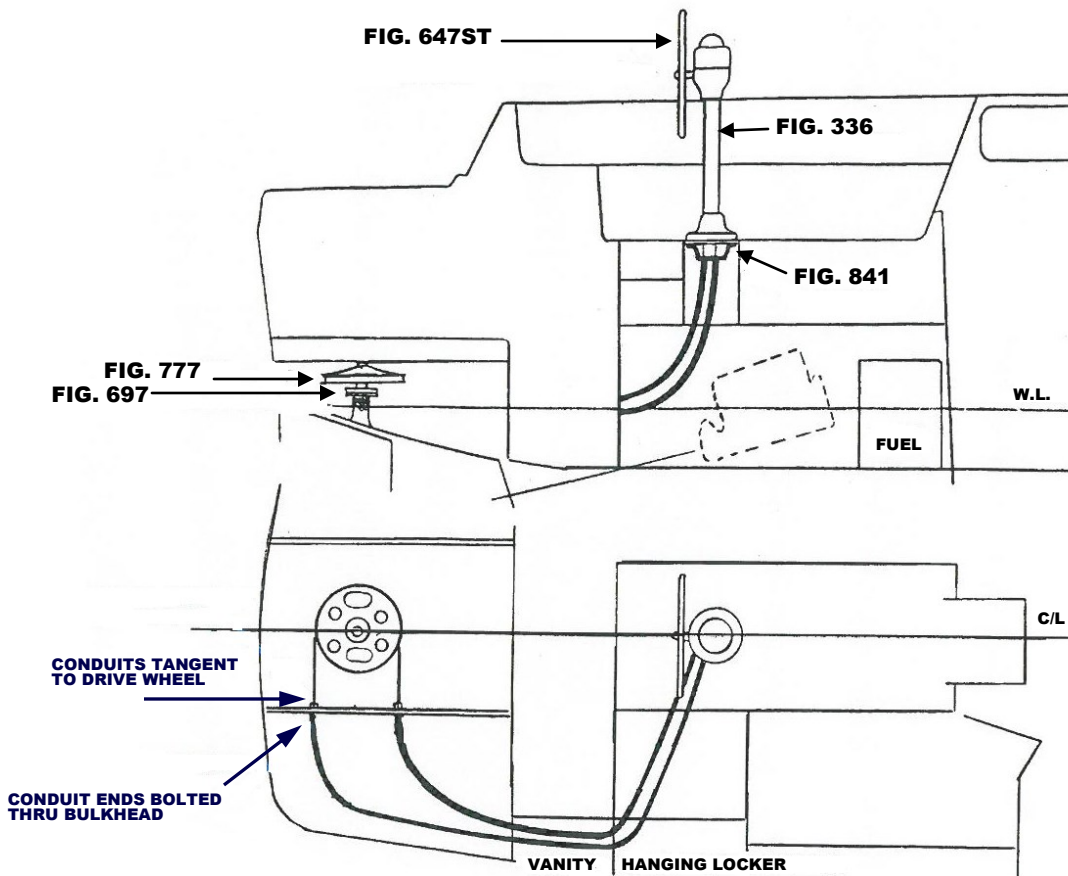

STEERING COMPONENTS:

- 1 FIG. 336-5-211T
- 1 FIG. 647ST-24-5
- 1 FIG. 77231

- 2 FIG. 797-10
- 1 FIG. 841-2
- 1 FIG. 777-8

- 4 FIG. 646-4HEX

(A FIG. 697 STUFFING BOX/BEARING MAY BE REQUIRED)

CLASSIC PEDESTAL STEERER/TAPERED

DISHED DESTROYER WHEEL

CUSTOM CHAIN & WIRE ROPE KIT W/HARDWARE *[was 774-KIT]*
(1.5FT #50 CHAIN, 14FT 3/16" 7X19 305 SS WIRE ROPE)

PULL/PULL CONDUIT W/END FITTINGS

DROP CONDUIT BRACKET

RADIAL DRIVE WHEEL

PEDESTAL MOUNTING BOLTS



146 DUCHAINE BLVD, NEW BEDFORD, MA 02745-1292 Tel: 508-995-9711 Fax: 508-995-5021 FREE FAX: 800-338-5021

S-2 8.0 MID-SHIP COCKPIT
(PULL/PULL CABLE SYSTEM)